

# HAFCO WOODMASTER

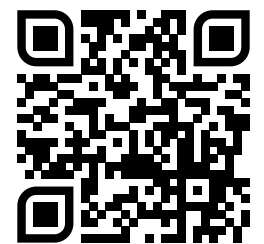
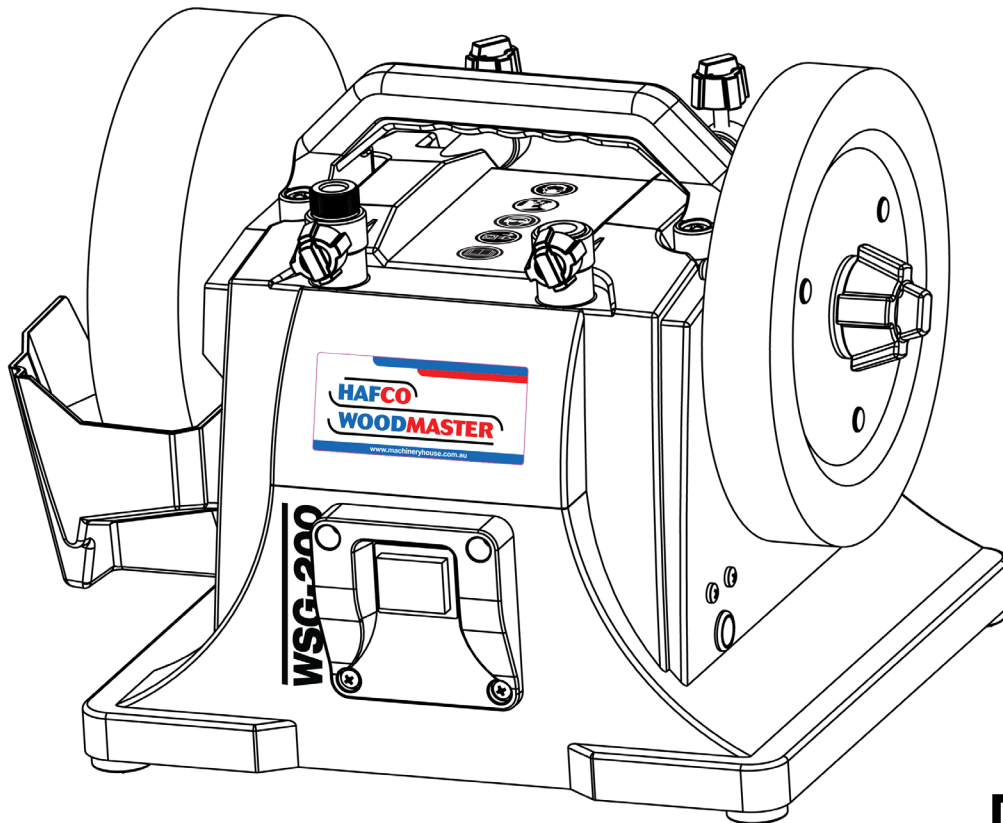

Edition : 1  
Date: (06/26)

## Instruction Manual

# WET STONE GRINDER WSG-200

Order Code: (W650)

**MACHINE DETAILS**

MACHINE.	WET STONE GRINDER
MODEL NO.	WSG-200
SERIAL NO.	
DATE OF MANF.	

IMPORTED BY



[www.machineryhouse.com.au](http://www.machineryhouse.com.au)



[www.machineryhouse.co.nz](http://www.machineryhouse.co.nz)

**NOTE:**

This manual is only for your reference. At the time of the compiling of this manual every effort to be exact with the instructions, specifications, drawings, and photographs of the machine was taken. Owing to the continuous improvement of the HAFCO Woodmaster machine, changes may be made at any time without obligation or notice. Please ensure the local voltage is the same as listed on the specification plate before operating any electric machine.

**SAFETY SYMBOLS:**

The purpose of safety symbols is to attract your attention to possible hazardous conditions



**WARNING** Indicates a potentially hazardous situation causing injury or death



**CAUTION** Indicates an alert against unsafe practices.

**Note:** Used to alert the user to useful information



**NOTE:**

In order to see the type and model of the machine, please see the specification plate. Usually found on the back of the machine. See example (Fig.1)

Fig.1

**HAFCO**  
**WOODMASTER**

---

**PRODUCT SPECIFICATIONS**

Model: WSG-200	Voltage: 240V/50Hz
Nett Weight: 9kg	Motor: 0.2HP/0.15kW
MFG Date:	FLC: 0.7A

Serial No:

---

Imported by Made in China  
[www.machineryhouse.com.au](http://www.machineryhouse.com.au) [www.machineryhouse.co.nz](http://www.machineryhouse.co.nz)

## GENERAL SAFETY RULES



### **WARNING!**

*Read and understand the instructions in this manual, before operating this machine to reduce the risk of serious injury or even death. Save all warnings and instructions for future reference.*

### **WORK ENVIRONMENT**

1. Keep the work area clean, tidy and well lit. Cluttered and dark areas invite accidents
2. Do not operate power tools in explosive atmospheres, such as in the presence of flammable liquids, gases or dust. Power tools create sparks which may ignite the dust or fumes.
3. Keep children and bystanders away while operating a power tool. Distractions can cause you to lose control.

### **PERSONAL SAFETY**

1. Stay alert, watch what you are doing and use common sense when operating a power tool. Do not use a power tool while you are tired or under the influence of drugs, alcohol or medication. A moment of inattention while operating power tools may result in personal injury.
2. Avoid accidental starting. Ensure the switch is in the OFF position before plugging the machine into the power supply. Plugging in power tools that have the switch ON invites accidents.
3. Do not overreach. Keep proper footing and balance at all times. This enables better control of the power tool in unexpected situations.
4. Dress properly. Do not wear loose clothing or jewellery. Keep your hair, clothing and gloves away from moving parts. Loose clothes, jewellery or long hair can be caught in moving parts.
5. Gloves, manufactured to the current Australian safety standards should be worn when operating grinding equipment.
6. Eye protection manufactured to the current Australian safety standards should be worn when operating grinding equipment. Eye protectors must provide protection from flying particles from the front and the side.

### **GENERAL USE AND CARE OF POWER TOOLS**

1. ALWAYS check for any damage or condition that could affect the sharpener's operation. Any damaged part should be properly repaired.
2. NEVER use the sharpener if it is defective or operating abnormally.
3. NEVER abuse the mains cable. Never pull on the cable to disconnect it from the power socket. Keep the cable away from sharp edges/hot surfaces.
4. NEVER carry out any alterations or modifications to this product.
5. NEVER wipe the sharpener clean with solvents. Wipe plastic parts with a soft cloth, slightly dampened with soapy water.
6. Do not use the tool for any purpose than that described in this manual.



### **WARNING!**

*DO NOT operate any machine before it is fully assembled and all the safety guards have been fitted and secured. Failure to do so may cause death or severe injury.*

### **ELECTRICAL SAFETY**

1. Power tool plugs must match the outlet. Never modify the plug in any way. Do not use adapter plugs with earthed (grounded) power tools. Correct plugs and matching outlets will reduce the risk of electric shock.
2. Do not abuse the cable. Never use it for carrying, pulling or unplugging the power tool. Keep the cable away from heat, oil, sharp edges or moving parts. Damaged or entangled cables increase the risk of electric shock.
3. Do not expose power tools to rain or wet conditions. Water entering a power tool will increase the risk of electric shock. If operating the power tool in a damp location is unavoidable, use a residual current device (RCD) protected supply.
4. When operating a power tool outdoors, use an extension cable suitable for outdoor use. Use of a cable suitable for outdoor use reduces the risk of electric shock.

### **GRINDING STONE SAFETY**

1. Check the speed of the grindstone before fitting to your grinder. Never use a stone with a rpm speed less than the rpm speed of your grinder. See specification.
2. The outside diameter and thickness of your accessories must be within the capacity rating of the power tool. The correct size accessories can be correctly guarded and controlled.
3. Never use a stone that is chipped, cracked or damaged. Fragments from a broken or damaged grinding stone can cause serious injury. Make sure that defective stones are destroyed and not used.
4. Bonded abrasive products are breakable and shall therefore be handled with utmost care. The use of damaged or improperly mounted or used abrasive products is dangerous and can cause serious injuries.
5. Always refer to the label for specified usage and observe the safety information. Do not use for purposes other than specified.
6. Always use the correct stone for it's intended task. Using the incorrect stone can cause serious injury.
7. Allow the stone and tool to do the work. Never force the workpiece against the stone as this could cause kickback and/or shatter the stone causing serious injury.
8. Do not use separate reducing bushes or adapters to adapt large hole abrasive wheels. Do not force a stone onto a machine or alter the size of the arbor hole.
9. Never use a damaged grinding stone. Inspect the stone before each use for chips, cracks or excess wear. If the tool or accessory is dropped, inspect for damage or install a new accessory. After fitting the accessory, position yourself away from the plane of the rotating accessory and run the tool at full speed. damaged stones may break apart during this test.
10. Abrasive products must be handled and transported with care. They should be stored in such a manner that they are not subjected to mechanical or environmental damage.



### **WARNING!**

*There is potential danger when operating any machine. Accidents are frequently caused by failure to pay attention or a lack of familiarity. Always use the machine with respect and caution to reduce the risk of operator injury. When normal safety precautions are overlooked or ignored, serious personal injury can occur.*

### SHARPENER SAFETY WARNINGS

1. Hold a hand tool or blade being sharpened firmly to prevent loss of control.
2. Never install a abrasive flap wheel or sanding disc on this sharpener.
3. Always replace a cracked grinding wheel immediately.
4. Never use damaged or incorrect grindstones. The stone and retaining fixtures were specially designed for your grinder, for optimum performance and safety of operation. Inspect the condition of the grinding stone before use and do not use if any damage is found.
5. Always use the tool rests to steady the workpiece. If the tool attachments are not used, the torque of the spinning grinding/polishing wheel may pull the workpiece from your hands.
6. Never leave the sharpener unattended when it is connected to an electrical power supply. Switch off the machine and unplug it before leaving.
7. ALWAYS check for damaged parts. Before further use any part that is damaged should be carefully checked to determine if it would operate properly and perform its intended function. Check for misalignment or binding of moving parts, breakage of parts and any other condition that may affect the tool's operation. A part that is damaged should be properly repaired or replaced at an authorized service center. Following this rule will reduce the risk of electric shock, fire or serious injury.

**NOTE: Bench grinders/sharpeners used in industrial environments may be subject to the requirements of The Provision and Use of Work Equipment regulations 1992 (particularly regarding the training requirement of The Abrasive Wheels Regulations 1970), or other legislation. If in doubt seek advice.**

**Please keep these instructions in a safe place for future reference.**

### SPECIFICATIONS

Order Code	W650
<b>MODEL</b>	<b>WSG-200</b>
Grinding Stone Dimensions (D x T)	Ø200 x 40mm
Spindle Diameter	12mm
Honing Wheel Dimensions (D x T)	Ø200 x 30mm
Honing Wheel Bore	12.5mm
No Load Speed	115rpm
Power	240V / 10A
Motor	150W
Weight	9kg
Dimensions (L x W x H)	430 x 370 x 340mm

**PACKING LIST**

- Ø200 x 40mm wet stone grinding wheel. 12mm bore, #220 grade
- Ø200 x 30mm leather honing wheel
- Universal jig
- “F” mounting bar.
- Angle Guide
- WSG-200 Wet stone grinder

Supplied in a carton with “honeycomb” type internal packaging.

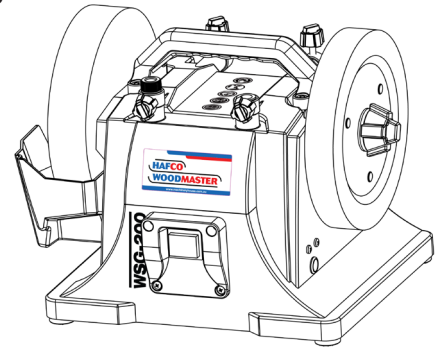

**IDENTIFICATION**

Become familiar with the names and locations of the controls and features shown below to better understand the instructions when mentioned later in this manual.

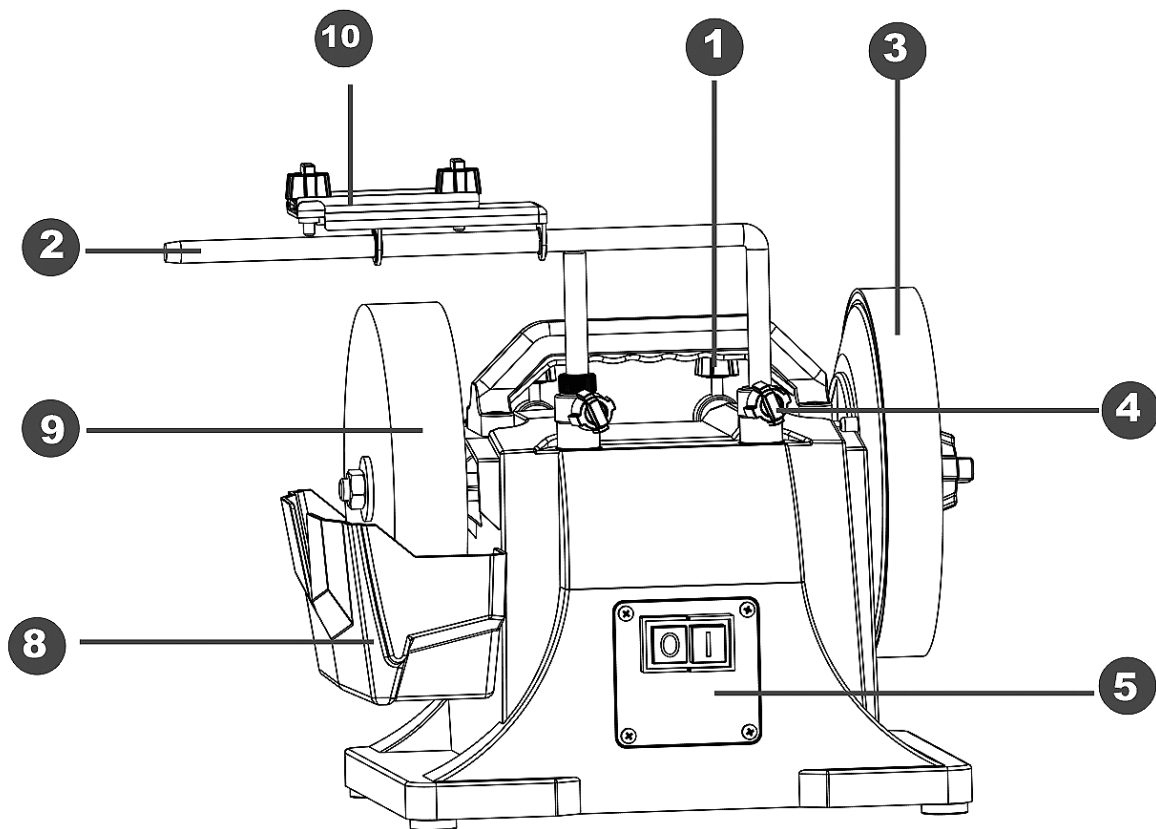

<b>1</b>	Horizontal Mounting Position
<b>2</b>	Universal Support
<b>3</b>	Leather Stropping Wheel
<b>4</b>	Vertical Mounting Position
<b>5</b>	ON/OFF Switch

<b>6</b>	Honing Compound (Not shown)
<b>7</b>	Angle Guide (Not shown)
<b>8</b>	Water Reservoir
<b>9</b>	Grinding Wheel
<b>10</b>	Grinding Jig

## ASSEMBLY

### FITTING THE TOOL SUPPORT

1. Insert the tool support into the two mounting holes at the top of the grinder as shown. (Fig. 2)
  - The tool support can be used to support the grinding jigs/ clamps, a truing or dressing tool, or as a tool or hand rest when working without jigs.

### VERTICAL GRINDING/HONING

1. Adjust the tool support to the desired height, before tightening the two knobs to secure it in position.

### HORIZONTAL GRINDING

1. Attach the tool support by inserting into the two mounting holes located on the rear of the grinder. Adjust to the desired height, before tightening the two knobs to secure it as shown. (Fig. 3)
2. Plug the machine into the nearest power supply.
3. Attach the water trough beneath the grinding stone. Fill the water trough with clean water up to the cut-out on the trough.

- The grinding stone must run in water at all times during operation and will become soaked with water. (Fig. 4)

4. Ensure the water trough is re-filled when necessary and discard any excess particles of stone which have accumulated in the water trough after extensive use.

- Avoid pouring the residue down a sink as this mass could eventually cause a blockage in the household plumbing.

5. To start/stop the grinder, press the ON/OFF switch.

- The grinder can run either forwards or backwards, selectable via a 3-position rocker switch. (Fig. 5)

Press the switch 'up' for reverse rotation (anti-clockwise when viewed from the grinding wheel end).

Press the switch 'down' for forward rotation (clockwise when viewed from the grinding wheel end).

6. Distribute the abrasive paste evenly onto the honing wheel with a suitable tool as shown. (Fig. 6)

7. This should be sufficient for five to ten tool honing tasks. This process should be repeated as required to ensure the long life of the honing wheel and achieve a good finish.

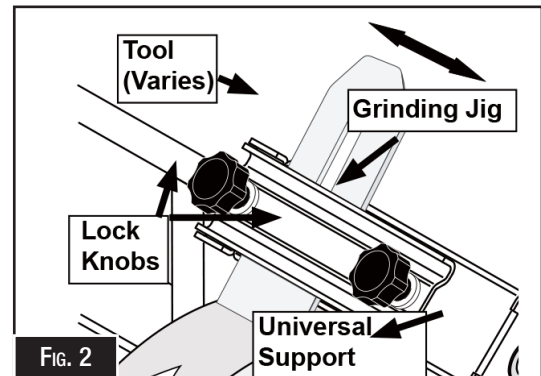

FIG. 2

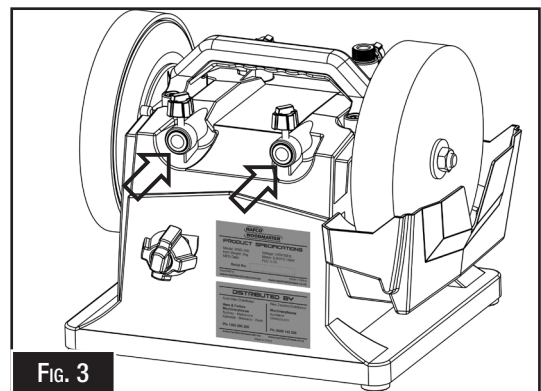

FIG. 3

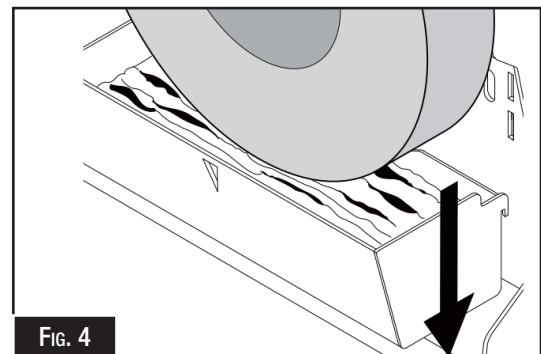

FIG. 4

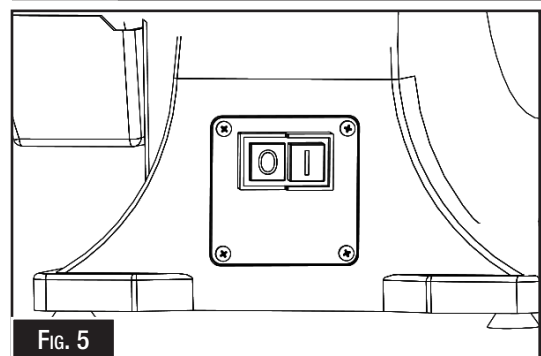

FIG. 5

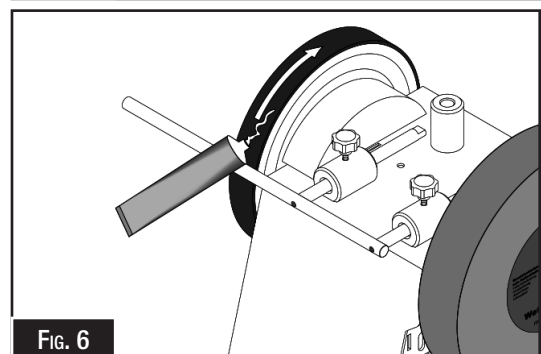

FIG. 6

## **WARNING!**



**WARNING:** fragments from a broken or detached grinding wheel can cause injury.

**WARNING:** ensure that the working position adopted does not cause operator fatigue which may lead to loss of control of the tool being ground.

**WARNING:** the stone will continue to rotate briefly after the switch has been pressed.

## **USING YOUR GRINDER**

### **GETTING STARTED**

The tool support can be used to support the tool clamp or be used for freehand grinding of any tools such as axes, pocket knives or woodcarving chisels that will not fit into the available tool holders.

### **USING THE TOOL CLAMP**

The tool clamp is designed for sharpening chisels and plane blades etc. When using the tool holder proceed as follows.

1. Slide the tool clamp onto the tool support.
2. Position the clamp directly above the grinding stone or honing wheel. Loosen the two knobs on the tool clamp. Insert the tool blade, bevelled end downwards in the tool clamp, then firmly tighten the blade in position as shown. (Fig. 7)
3. Adjust the tool support so that the tool clamp is a suitable distance from the grinding stone or honing wheel. Loosen the two knobs on the tool clamp to adjust the tool blade so that its edge lightly touches the grinding stone or honing wheel. The correct angle will be determined by using the Angle Guide as described below.
4. Switch on the grinder and slowly move the tool clamp back and forth along the tool support to grind the tool blade. If necessary, loosen the knobs on the tool clamp to re-adjust the blade. After adjustment, check that the angle is still correct.

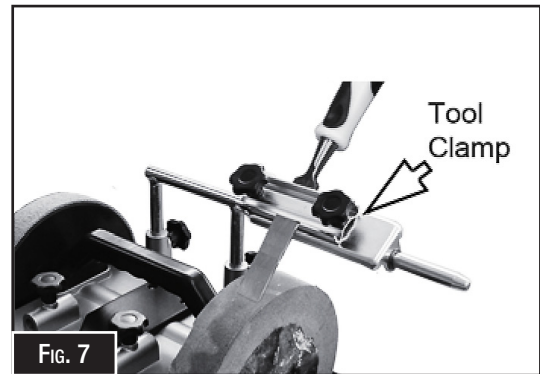

### **USING THE ANGLE GUIDE**

1. The angle guide is used to determine the cutting edge angle of a tool. To do so, secure the tool into the tool clamp, then install the clamp to the tool support as shown. (Fig.8)
2. With the machine switched off, hold the angle guide with the desired angle (as indicated on the angle guide) at the tool tip.
3. Adjust the height of the tool support so that the front end of the angle guide touches the grinding stone. Make sure the angle guide continues to touch the tool tip.
4. Once the desired angle is achieved, firmly lock the tool support in place and remove the angle guide.

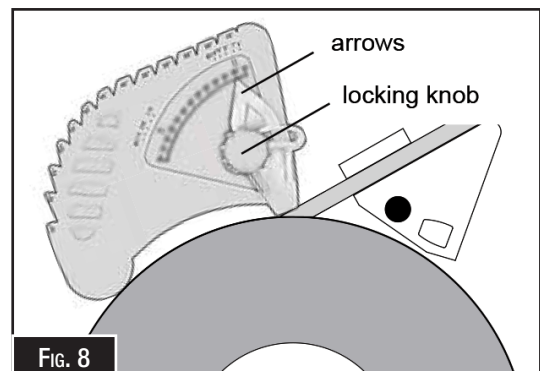

## USING YOUR GRINDER Cont.

### GRINDING/HONING A KNIFE BLADE

Two knife holders are supplied for sharpening knives of different lengths and stiffness. Knives will be sharpened with an equal bevel to each side of the blade as itemized on the angle guide.

When using the knife holders proceed as follows:

1. Loosen the knurled screw on the knife holder. Centre the tension plate along the top edge of the knife blade then firmly tighten the knurled screw to set the knife blade in position.
2. Tighten the knob to secure the knife blade tightly before starting work.
3. Set the knife holder on the tool support and adjust the tool support bar downward so that the knife blade lightly touches the grinding stone or honing wheel at the correct angle as determined by the angle guide.
4. Turn on the sharpener and grasp the knife holder firmly. Place the holder on the tool support and slowly move the knife holder back and forth along the tool support to grind/hone the knife blade. Steady your hand against the tool support as you work. The process will be repeated for the other side after resetting the knife in the holder. (Fig. 9)

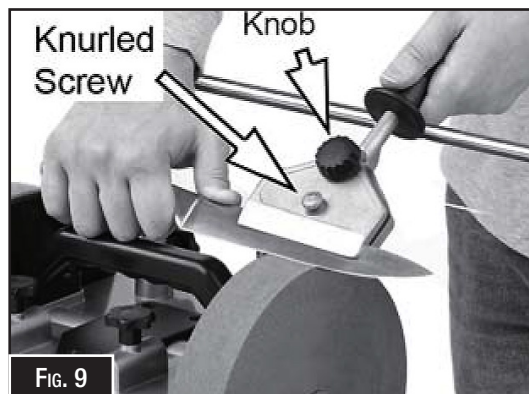

### GRINDING TIPS

- After setting the angle, switch on the grinder and start work.
- Press the tool blade evenly onto the stone and move the tool sideways across the stone. Make sure that at least half the width of the tool cutting edge comes into contact with the sharpening stone at any time to avoid damage to the stone.
- Allow the stone to do the work. Do not apply excessive downward pressure on the tool when grinding.
- Make sure the level of water in the tank is adequate. Never attempt to dry grind.

### HONING TIPS

- Never hone against the direction of the honing wheel, which would cause the tool to cut into the leather honing wheel surface. (Fig.10)
  - Although you can work “freehand” for the honing process, you will achieve more precise results by securing the tool with the tool clamp or tool holder, and setting the honing angle to the angle used when grinding the tool.
- Press the tool evenly onto the honing wheel near the cutting edge, and move the tool sideways across the wheel. Ensure that at least half the width of the cutting edge comes into contact with the wheel at any time to avoid damage to the wheel.
  - Allow the wheel to do the honing, without applying excessive downward pressure on the tool.
  - Always ensure the honing wheel is kept saturated with machine oil and abrasive paste for best results.

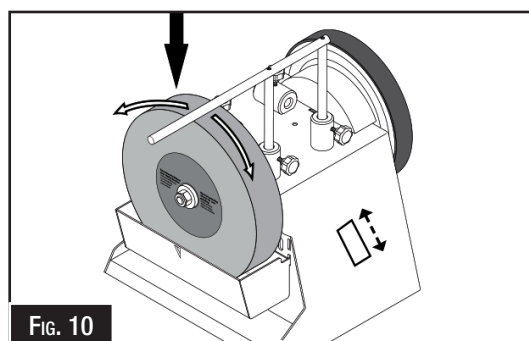

## MAINTENANCE

### GENERAL MAINTENANCE

Make sure that all components are tight and secure. Always have any damaged or worn parts repaired or replaced by qualified service personnel.

The honing wheel may develop a bump after extensive use where the glued joint in the leather covering stands proud as the leather becomes compressed. This can be corrected by sanding away the high spot with an abrasive (sandpaper) block.

The stone will wear down with use and may well go out of true. Use a dressing wheel or stone grader to correct the trueness and to remove worn, glazed grains from the stone.

The stone will have a finite life expectancy, dependent upon the nature of the work being done. Periodically, make a note of the wheel diameter and replace your 8" (200mm) dia wheel if it reduces to as little as 7" (180mm) in diameter.

### INSTALLING A NEW GRINDING STONE

1. Unscrew and remove the locknut and washer that secures the stone in place.
2. Remove the old grinding stone and fit the replacement, securing it with the locknut and washer. Grasp the honing wheel to prevent the drive shaft from turning while tightening the nut.

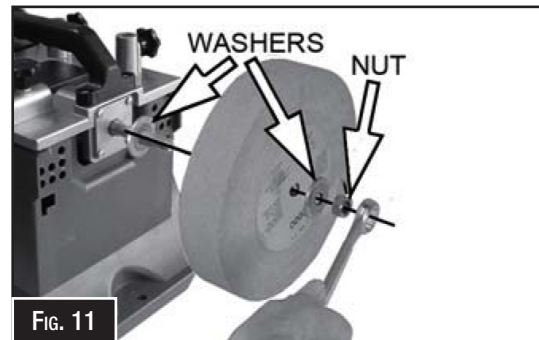

FIG. 11

### DRESSING A NEW STONE

New grinding stones are frequently not true or in time can become grooved, glazed (built-up), out of round or otherwise incorrectly sharpened.

1. If the grinding stone is new, allow it to spin for a minute with no load. Check that it is spinning straight and true. If not, it will require dressing before use.
2. Stand to the side of the stone and hold the dresser handle firmly. Place the dresser on the tool support so that its wheels can move freely (i.e., the exposed part of the wheel should be facing up). Run the stone and apply the dresser to the surface of the stone.

### INSTALLING A NEW HONING WHEEL

1. Unscrew and remove the hand nut and washer that secures the honing wheel in place.
2. Remove the old honing wheel and fit the replacement, securing it with the hand nut and washer. Ensure the drive pin, rests in the groove in the hidden face of the honing wheel.

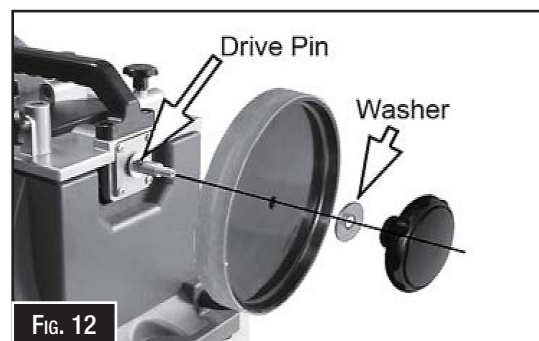

FIG. 12

### CLEANING & STORAGE

Clean the exterior of the machine if required using a mild detergent or mild solvent. Never immerse the machine in water.

To reduce any fire hazard, keep the cooling vents below the grinder free of debris.

If not bolted to a workbench, store the grinder in a clean, dry location, out of reach of children.





#### ENVIRONMENT PROTECTION

Recycle unwanted materials instead of disposing of them as waste. All tools, accessories and packaging should be sorted, taken to a recycling centre and disposed of in a manner which is compatible with the environment. When the product becomes completely unserviceable and requires disposal, drain any fluids (if applicable) into approved containers and dispose of the product and fluids according to local regulations.

IMPORTED BY

**HARE & FORBES**  
**MACHINERYHOUSE**

Australian Distributor

**Hare & Forbes**  
**Machineryhouse**  
Sydney - Melbourne  
Adelaide - Brisbane - Perth

**Ph: 1300 202 200**  
**[www.machineryhouse.com.au](http://www.machineryhouse.com.au)**

**MACHINERYHOUSE**

New Zealand Distributor

**Machineryhouse**  
Auckland  
Christchurch

**Ph: 0800 142 326**  
**[www.machineryhouse.co.nz](http://www.machineryhouse.co.nz)**